

HVM CONNECTOR

Board-to-wire

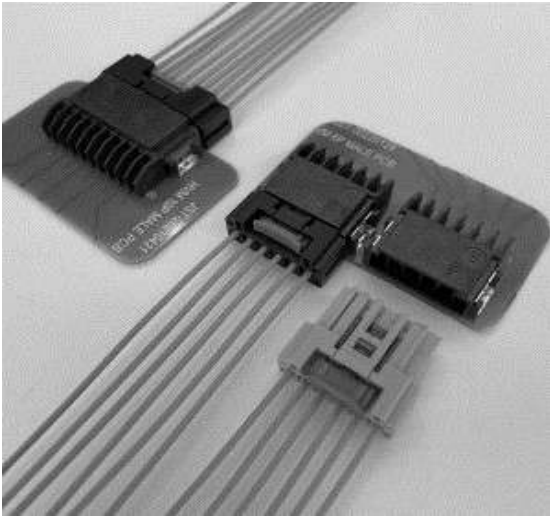

Developed in pursuit of withstanding high voltage, miniaturization and low profile as surface mounting type connector for automotive.

To realize the withstanding voltage and miniaturization by flange structure and pitch 3.5/4.0mm design.

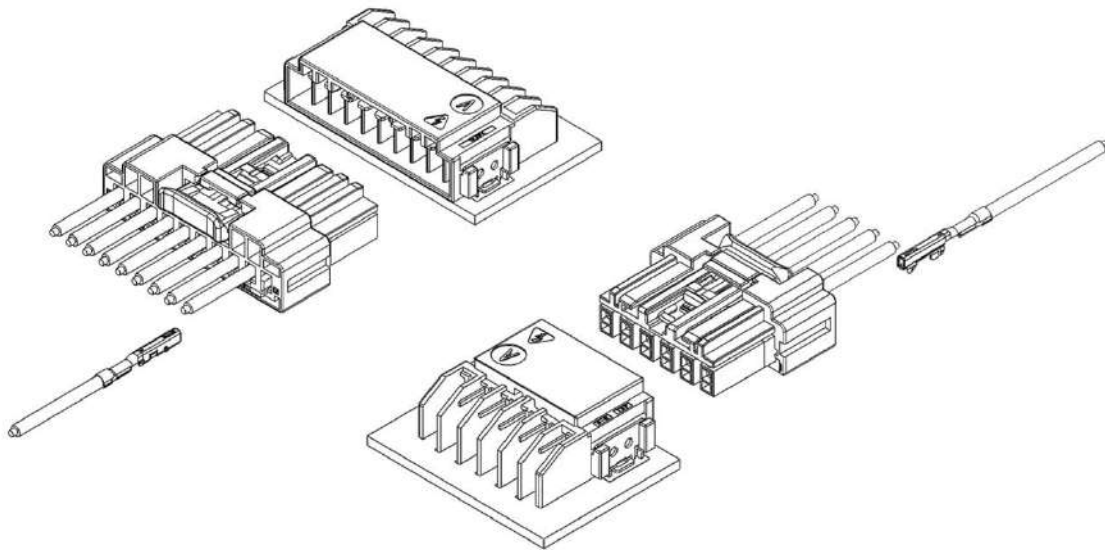

■ Features

- **Withstanding high voltage·Miniaturization·Low profile**
Flange structure design enable withstanding high voltage.
The miniaturization is realized.
- **Connector Position Assurance (CPA) Design**
- **UL94 V-0 material**
In response to increasingly stringent requirements for flammability.
Use resin that supports UL94 V-0.

■ Specifications

- Current rating : 5A AC, DC max
- Rated voltage : 1,000V AC / DC (10 circuits)
1,250V AC / DC (6 circuits)
- Withstanding voltage : 3,000VAC / minute (10 circuits)
3,500 VAC / minute (6 circuits)
- Temperature range : -40°C to +125°C (gold- plated)
-40°C to +105°C (tin- plated)
(including temperature rise in applying electrical current)
- Contact resistance : Initial value / 20 mΩ max.
After environmental tests/ 20 mΩ max.
- Insulation resistance : 200 MΩ min.
- Applicable wire : 0.3mm² to 0.5mm² , O.D. Ø1.4 to 1.8mm
(High voltage cable)

*Compliant with ELV/RoHS.

*Contact JST for details.

Female terminal

● 0.64 Female terminal S

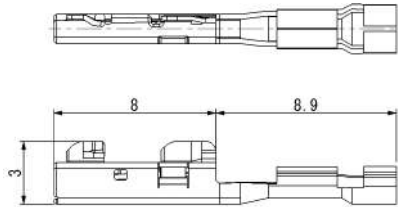

Model No.	Applicable wire range		Q'ty/reel
	Conductor (mm ²)	Insulation O.D. (mm)	
①SNAC3-A021T-M0.64	0.3 to 0.5	1.4 to 1.8	5,000
②SNAC3-A021GF-M0.64-1	0.3 to 0.5	1.4 to 1.8	5,000

Material and Finish

- ①Copper alloy, nickel-undercoated, tin-plated
- ②Copper alloy, nickel-undercoated, Contact area: gold-plated
Barrel area: tin-plated

Female connector

● 6 circuits

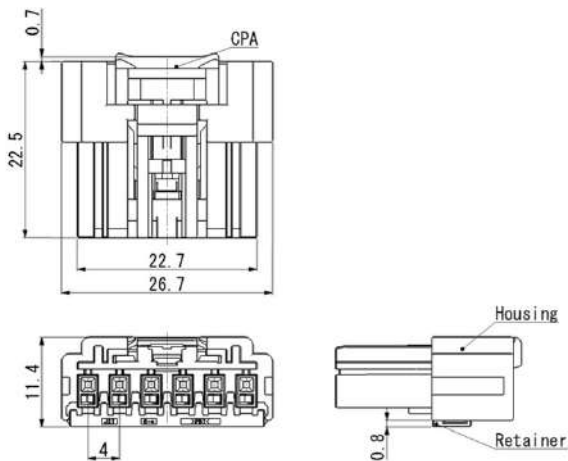

● 10 circuits

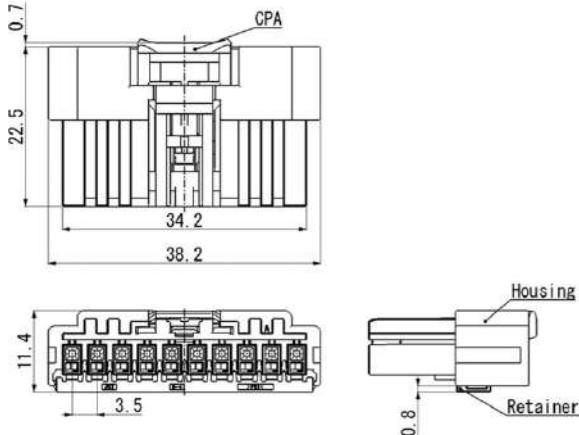

Circuits	Model No.	Housing Color	Q'ty/box
6	06HVM-BC-1A-K-A	Black	550
	06HVM-BC-1A-D-B	Orange	550
10	10HVM-BC-1A-K-A	Black	400
	10HVM-BC-1A-D-B	Orange	400

Material and Finish

Housing: Glass-filled PBT (UL94 V-0)
 Retainer: Glass-filled PBT, Blue (UL94 V-0)
 CPA: Glass-filled PBT, Green (UL94 V-0)

Note: Color/Key codes other than above mentioned housing are also available.
 Contact JST for details.

Male connector

SMT type

● 6 circuits

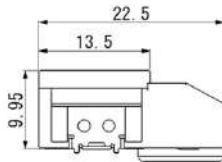
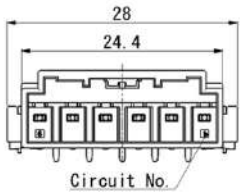
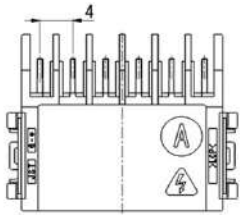

● 10 circuits

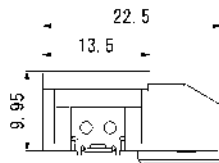
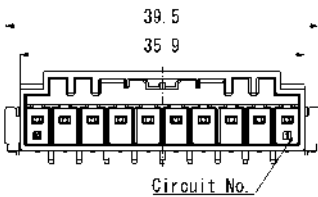
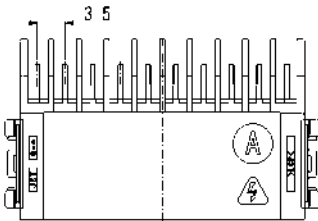

Circuits	Model No.	Housing Color	Q'ty/box
6	①SM06B-HVMK-1A-A	Black	800
	②SM06B-HVMK-1AGF-A	Black	800
	①SM06B-HVMK-1A-B	Black	800
	②SM06B-HVMK-1AGF-B	Black	800
10	①SM10B-HVMK-1A-A	Black	510
	②SM10B-HVMK-1AGF-A	Black	510
	①SM10B-HVMK-1A-B	Black	510
	②SM10B-HVMK-1AGF-B	Black	510

Material and Finish

Housing: Glass-filled LCP, Black (UL94 V-0)

Pin: ①Copper alloy, nickel-undercoated, tin-plated

②Copper alloy, nickel-undercoated, Contact area: gold-plated

Solder tail: tin-plated

Tab: Brass, nickel-undercoated, tin-plated

Note: Key codes other than above mentioned housing are also available.
Contact JST for details.

Taping specifications

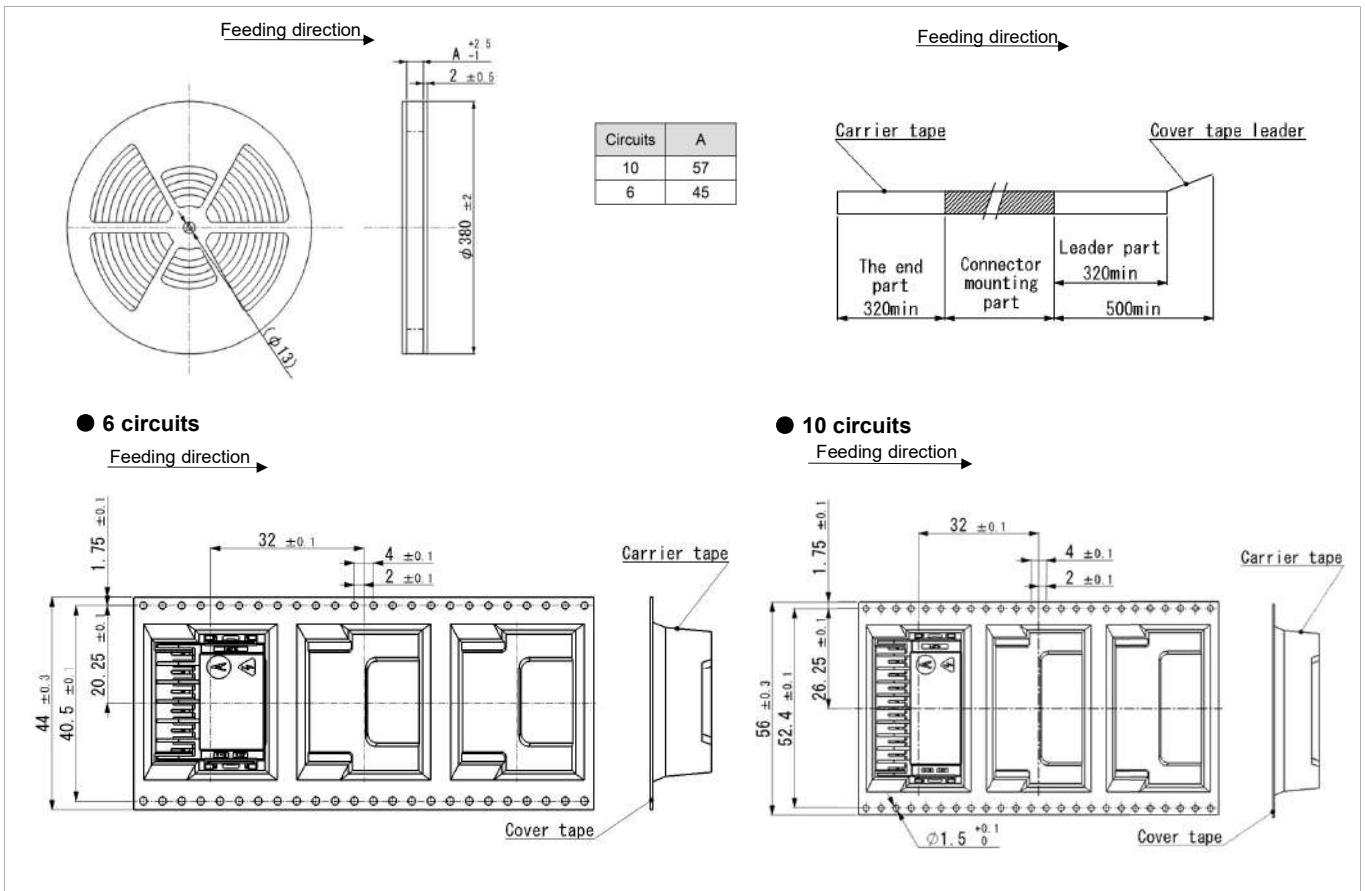

PC board layout, Assembly layout

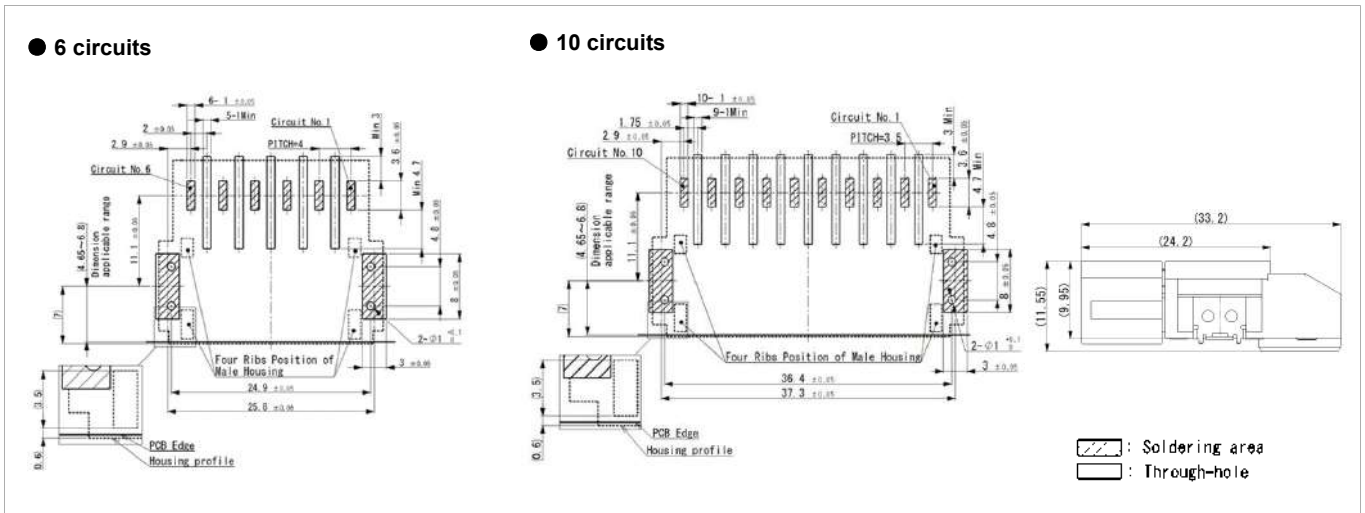

Note: 1. Tolerances are non-cumulative: $\pm 0.05\text{mm}$ for all centers.
 2. Hole dimensions differ according to the type of PC board and piercing method.
 The dimensions above should serve as guideline. Contact JST for details.

Crimping machine, Applicator

Strip terminal	Crimping machine	Crimp applicator MKS-L	
		Dies	Crimp applicator with dies
SNAC3-A021T-M0.64	AP-K2N	MK/SNAC3-A021-064	APLMK SNAC3-A021-064
SNAC3-A021GF-M0.64-1			

Note: 1. Contact JST for details.
 2. When crimping operation is conducted using an applicator and die set other than the above, JST cannot guarantee the performance of the terminal.