

LC-L CONNECTOR

Disconnectable Crimp style connectors

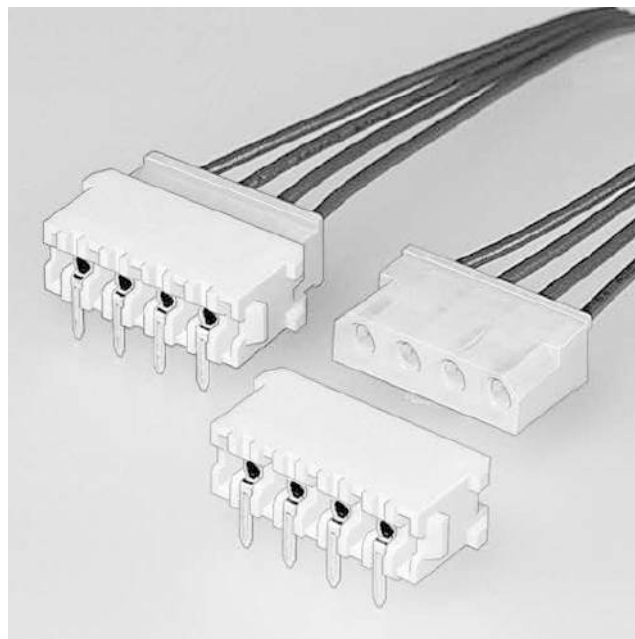

The LC connector is for the secondary power circuit used in the office automation equipment, such as the 3.5inch HDD and MO, including the DVD.

This low-profile crimp type connector is designed to meet further miniaturization of the equipment.

The Plug Housing can also be mated with our LC connector (top and side entry types) and the power connection part of the LK connector.

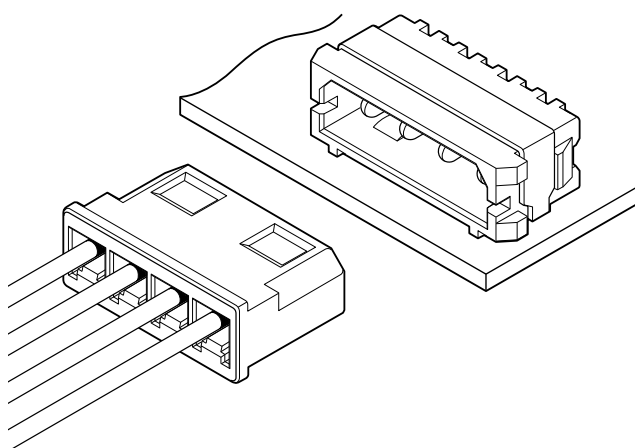

Features

• Space-saving

The miniaturization (improved from 20.5mm to 13.5mm height) realizes radical space saving after mating and consequently will provide more space for wiring.

• Lower insertion force

Insertion and withdrawal force are reduced by 40 to 50% compared to the existing type.

• Double-crimping contact

For an internal branching or jumper connection, a double-crimping type contact is adopted.

Specifications

- Current rating: 5A AC, DC (AWG#20)
- Voltage rating: 250V AC, DC
- Temperature range: -25°C to +90°C
(including temperature rise in applying electrical current)
- Contact resistance: Initial value/10mΩ max.
After environmental testing/20mΩ max.
- Insulation resistance: 1,000MΩ min.
- Withstanding voltage: 1,500V AC/minute
- Applicable wire: 001 type: AWG#26 to #22, #26+#26
02 type: AWG#20 to #18, #26+#24,
#24+#24, #24+#22, #22+#22
- Applicable PC board thickness: 1.6mm
- Number of circuits: 4
- * Compliant with RoHS.
- * Refer to "General Instruction and Notice when using Terminals and Connectors" at the end of this catalog.
- * Contact JST for details.

LC-L CONNECTOR

Contact

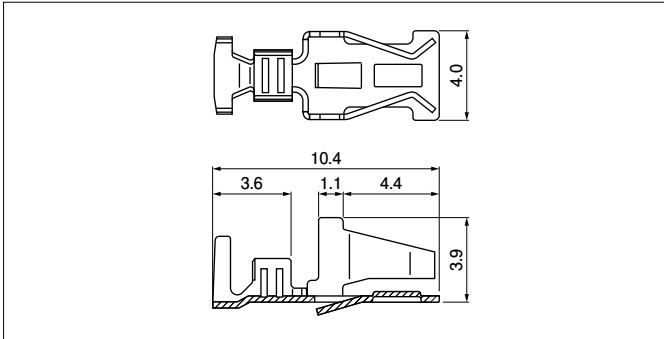

Model No.	Applicable wire			Q'ty / reel
	mm ²	AWG #	Insulation O.D. (mm)	
SLC-001T-P2.0	0.13 to 0.33	26 to 22	1.3 to 1.7	3,000
	0.13 + 0.13	26 + 26	1.3 + 1.3	
SLC-02T-P2.0	0.5 to 0.75	20 to 18	1.9 to 2.1	3,000
	0.13 + 0.22 to 0.33 + 0.33	26 + 24 to 22 + 22	1.3 + 1.5 to 1.7 + 1.7	

Material and Finish
Phosphor bronze, tin-plated (reflow treatment)

RoHS compliance

Housing

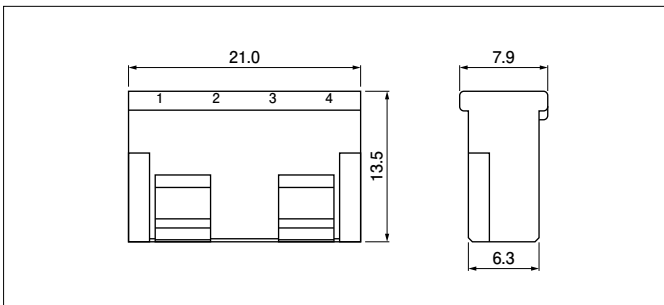

Model No.	Q'ty / bag
LCP-04L	500

Material
PA 66, UL94V-2

RoHS compliance

Header

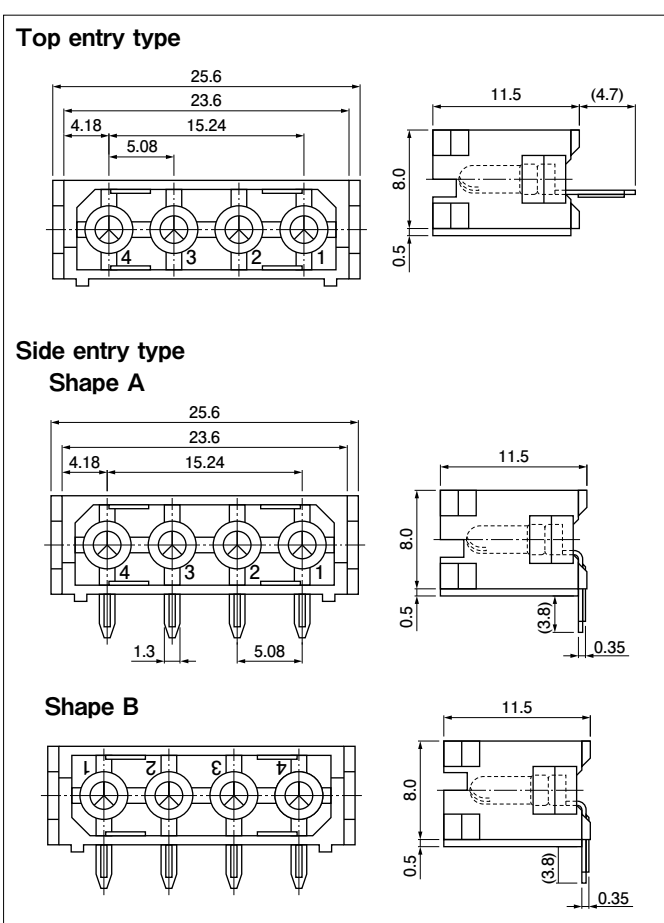

Top entry type

Model No.	Q'ty / box
LC-04T	100

Material and Finish
Contact: Brass, tin-plated (reflow treatment)
Housing: PA 66, UL94V-0, natural (white)

RoHS compliance

Side entry type

Shape	Model No.	Q'ty / box
A	LC-04A	100
B	LC-04B	

Material and Finish
Contact: Brass, tin-plated (reflow treatment)
Housing: PA 66, UL94V-0, natural (white)

RoHS compliance

LC-L CONNECTOR

Housing clamp

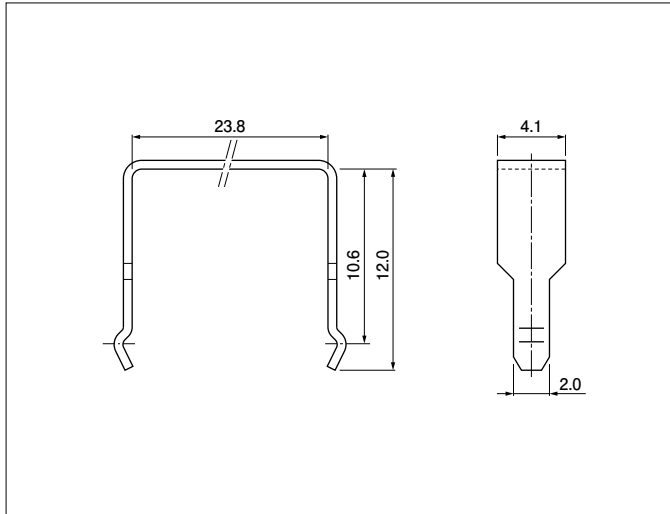

Model No.	Q'ty / box
LCC-04	500

Material and Finish

Brass, copper-undercoated, tin-plated (reflow treatment)

RoHS compliance

PC board layout (viewed from component side) and Assembly layout

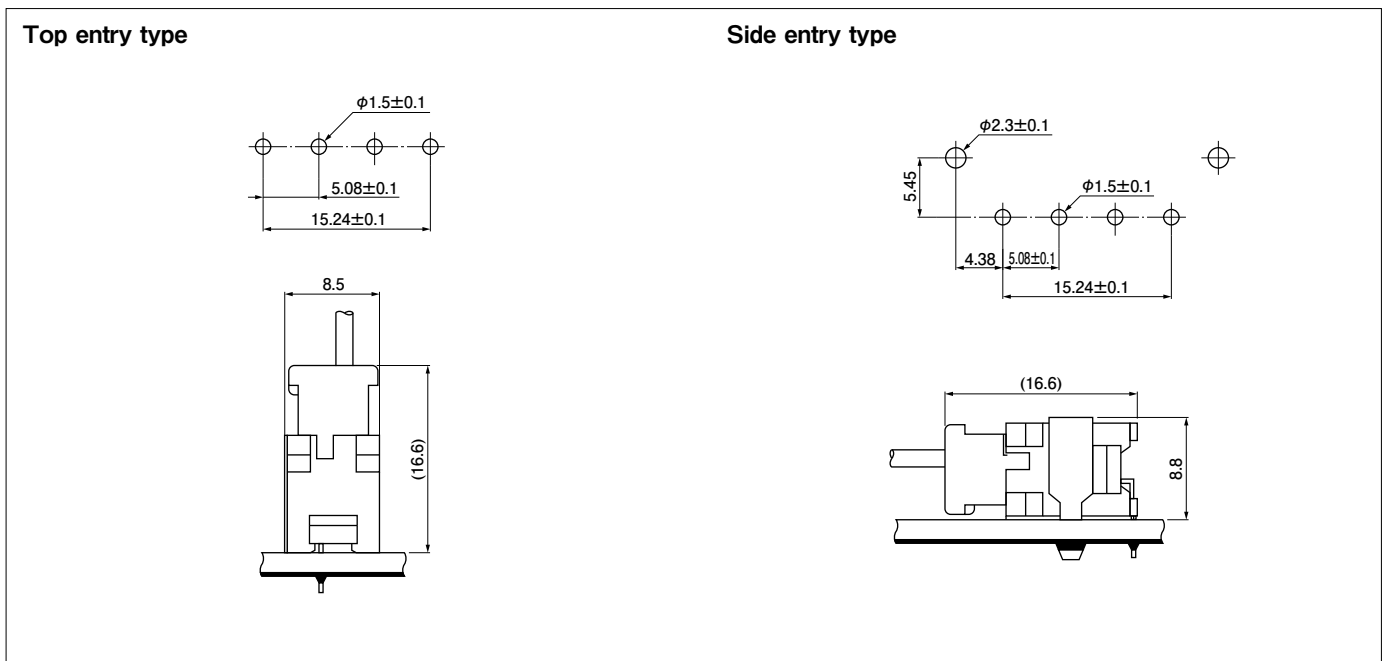

Note:

1. Tolerances are non-cumulative: ± 0.1 mm for all centers.

2. Hole dimensions differ according to the type of PC board and piercing method. The dimensions above should serve as a guideline. Contact JST for details.

Model number allocation

Contact

S LC - 001T - P 2.0

Form: S...Strip form

Series name

Applicable wire range:
 001...AWG #26 to #22, AWG #26 + #26
 02...AWG #20 to #18, AWG #26 + #24 to #22 + #22

Surface finish: T...Tin-plated (reflow treatment)

Material: P...Phosphor bronze

Terminal size

Housing

LCP - 04 L

Series name

Part name: Plug

No. of circuits: 4

Shape: L...Low-profile type

Header

LC - 04 T

Series name

No. of circuits: 4

Shape of assembled product: T...Top entry type
 A...Side entry type Type A
 B...Side entry type Type B

Housing clamp

LCC - 04

Series name

Part name: Clamp

No. of circuits: 4

Crimping machine, Applicator

Contact	Crimping machine	Applicator		
		Crimp applicator	Dies	Crimp applicator with dies
SLC-001T-P2.0	AP-K2N	MKS-L	MK/SLC-001-20	APLMK SLC001-20
SLC-02T-P2.0			MK/SLC-02-20	APLMK SLC02-20

Note: Contact JST for fully automatic crimping applicator.